

Installation Instructions – BMW M57/47N Stand Alone Harness

The wiring loom supplied has 7 connectors:

1. Plug for the Body Loom
2. ECU Connector
3. Throttle Pedal
4. Earth Ring
5. ECU supply & Ground
6. OBD II Connector (For diagnostic purposes)
7. CANbus connection
8. Fuel pump relay connector

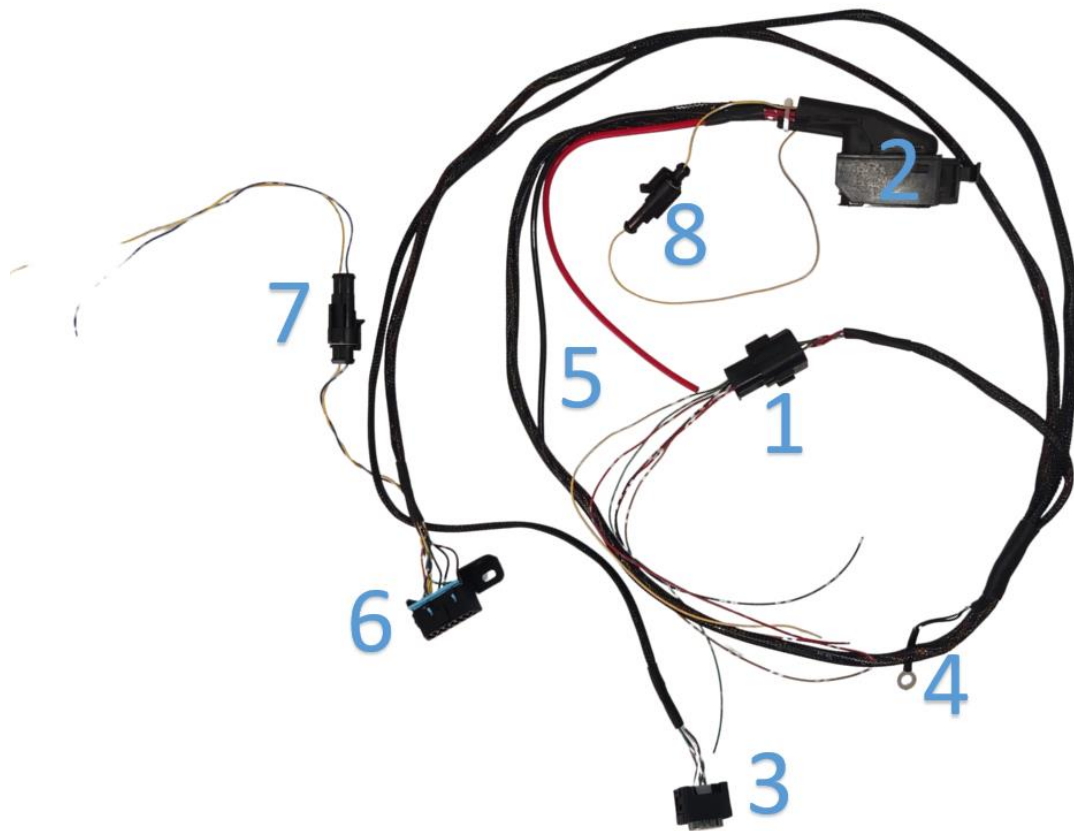

Body Loom Connection

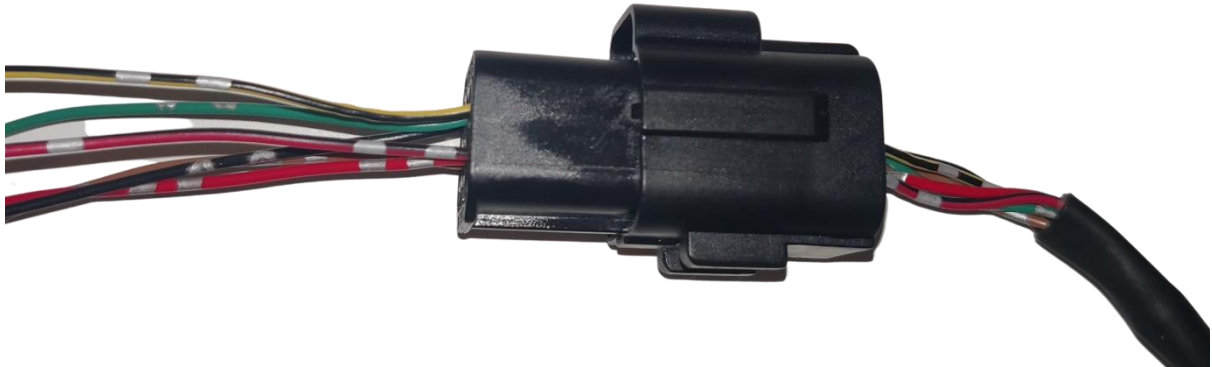

The wires used to connect to the body loom are shown in the table below. These must be securely connected through the appropriate protection.

Body Loom Connector		Wire Colour	Connection
Pin 1	Constant 12v	Yellow/Black	5A Fused
Pin 2	Ignition 12v	Red/Black	5A Fused
Pin 3	RPM	Green	Output to standard rpm gauge
Pin 4	Oil Pressure Lamp	Red	Connect to +12v through bulb
Pin 5	Brake switch NO	Black	Connection to brake switch or controller (if fitted)
Pin 6	Brake switch NC	Brown	Connection to brake switch or controller (if fitted)

- Pin 1 is a constant 12 volt supply from the car battery, this must supply power after the ignition is turned off. This should be fused to 5 Amps.
- Pin 2 is an ignition 12 volt and should be fused to 5 Amps.
- Pin 3 is an output RPM signal from the ECU.
- Pin 4 is an output from the loom to power an oil pressure lamp, this lights if the engine suffers a significant loss in oil pressure. Note, this may not work on all engines so we recommend checking that it works. If it doesn't, we recommend fitting an aftermarket oil pressure gauge.
- Pin 5 is explained below.
- Pin 6 is explained below.

Brake Switches

Pins 5 and 6 are for brake switches. These are required if fitting cruise control or if fitting an automatic transmission.

BMW, as standard, uses a brake switch with 2 different outputs. The logic that this follows is:

	Brake pedal not operated	Brake pedal operated
Status, brake-light switch (NC)	Closed	Open
Status of brake-light test switch (NO)	Open	Closed

When closed, the brake-light switch connects to earth (B-), the brake-light test switch connects to B+ (+12v).

This is quite confusing, and can be challenging to wire up manually as you would need 2 switches, or a relay.

To combat this, we have made a board which takes a single 12v input and converts it into the 2 signals that the ECU wants to see. These are available here: <https://house-of-torque.com/product/brake-switch-converter/>

Alternatively, it is possible to use the original BMW brake switch:



If you are using this, the pinout is as follows:

Brake switch pin	Function	Connect to
1	Power	12v Supply
2	Ground	Ground
3	Brake Light Switch	Body loom connector pin 6
4	Brake Light Test Switch	Body loom connector pin 5

Bosch Engine ECU Connection

This connector connects directly to the Engine ECU as shown in the picture below.



ECU Power

M57N engines

The free length **RED cable** at ECU connector must be connected to the **thick red/blue cable** exiting the engine harness. This feed is supplied by the blue DDE main relay built into the engine harness.

Additionally, the feed into the main relay is usually a single thick red/white wire, this should be connected to +12v:

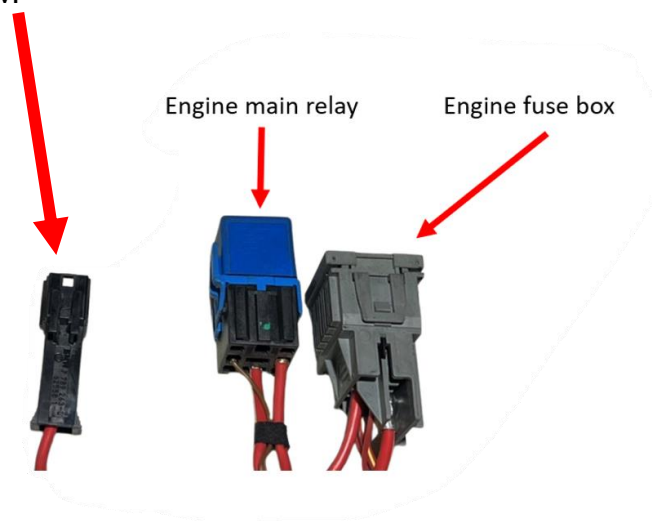

M57N2 engines

See final pages of this guide as the ECU power supply varies from model to model.

Fuel Pump

The Yellow/Blue wire provides fuel pump control. It is an ECU switched earth for a Fuel Pump Relay which in turn powers the fuel pump. Connect constant fused 12v to the '86' pin and the '85' to the yellow/blue wire.

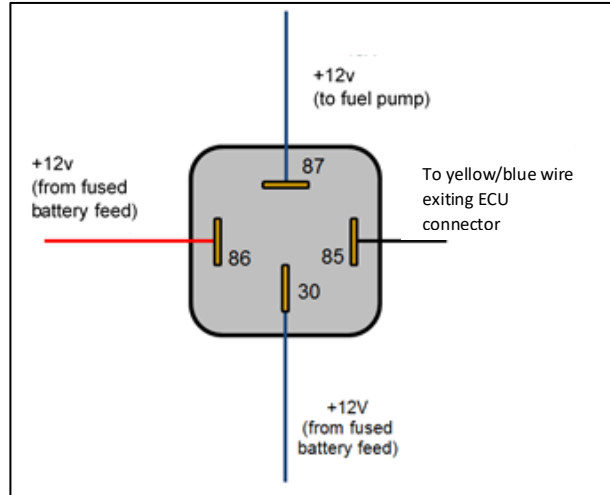
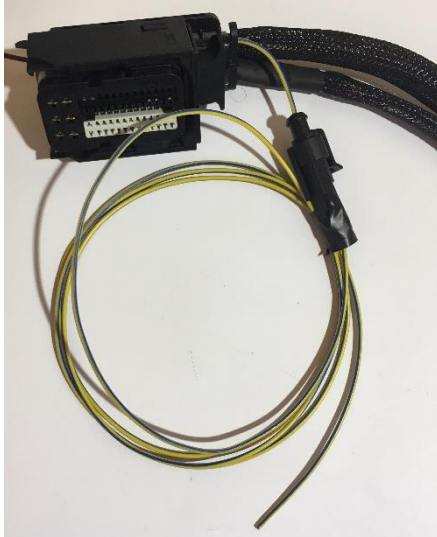

Throttle Pedal Connection

This connector connects directly to the Throttle Pedal as shown in the picture below.



Main Ground Connector*

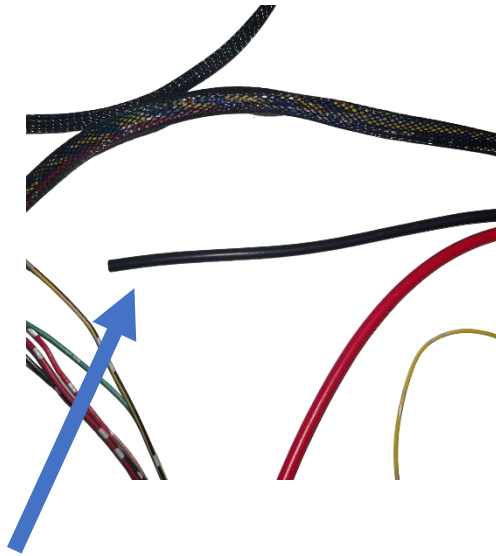

The free length of black wire exiting the main ECU connector should be connected to ground. This MUST be a secure and strong connection to ground to avoid problems later on. The ground terminal must be clean of rust, paint and dirt to ensure a solid ground connection is made.

*From April 2024 this wire is Blue

OBD Ground - Black Ring Terminal*

This ring terminal should be attached to a constant ground e.g. Battery (-) Terminal. This MUST be a secure and strong connection to ground. The ground terminal must be clean of rust, paint and dirt to ensure a solid ground connection is made.



*From April 2024 this has been removed and no longer required.

OBD II Connector

The OBD port is used for diagnostics and should be located inside the vehicle. It does not need to be connected to anything for the loom to function.

The 2 pin connector provides an optional connection to the engine CAN Bus.

Pin 1	Yellow - CAN High
Pin 2	Green or blue - CAN Low

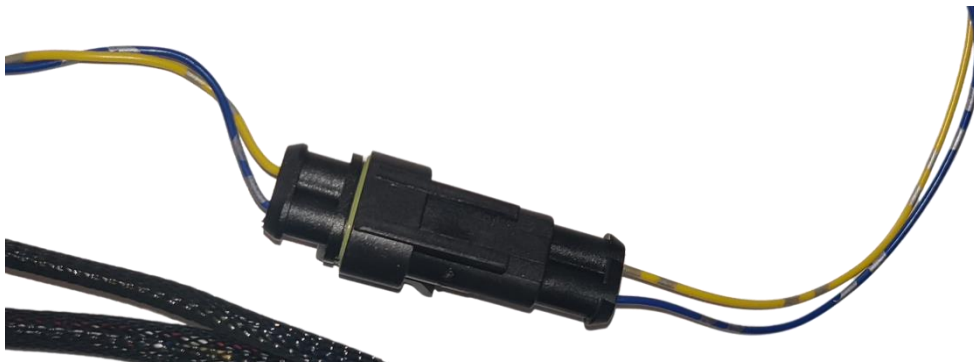

In addition, we have added an extra grey CAN Bus connector which can be used as an extra spur or to fit terminating resistors.

Other engine harness connections:

The following pages contain some example diagrams primarily for M57N2. Not every model is listed and there may be some differences from the diagrams. However, all engine looms follow the same principle, and in general, the wire colours will match.

For M57N engines, there is no MAF wire to connect. The starter motor is always a thick black wire. If you are unsure, check with a multimeter for continuity.

If you have any queries with the installation, please don't hesitate to contact us.

E60 TU2 Engine

A6011 Engine plug – connections needed

1. (Black) Starter motor signal
2. (Red/Blue) Main relay supply to ECU
3. (Red/Blue) Main relay supply to ECU
4. (Red/Blue) Main relay supply to ECU
5. Not required
6. (Red/white) Spare output from main relay
7. (Green) Main relay supply to MAF
8. Not required
9. Not required
10. Not required
11. Not required
12. Not required

Instructions:

- Connect pins 2, 3 & 4 to the main feed into the standalone harness which supplied the ECU with power.
- Connect your vehicle starter motor signal to pin 1.
- Connect the spare main relay feed (pin 6) to the MAF supply (pin 7)

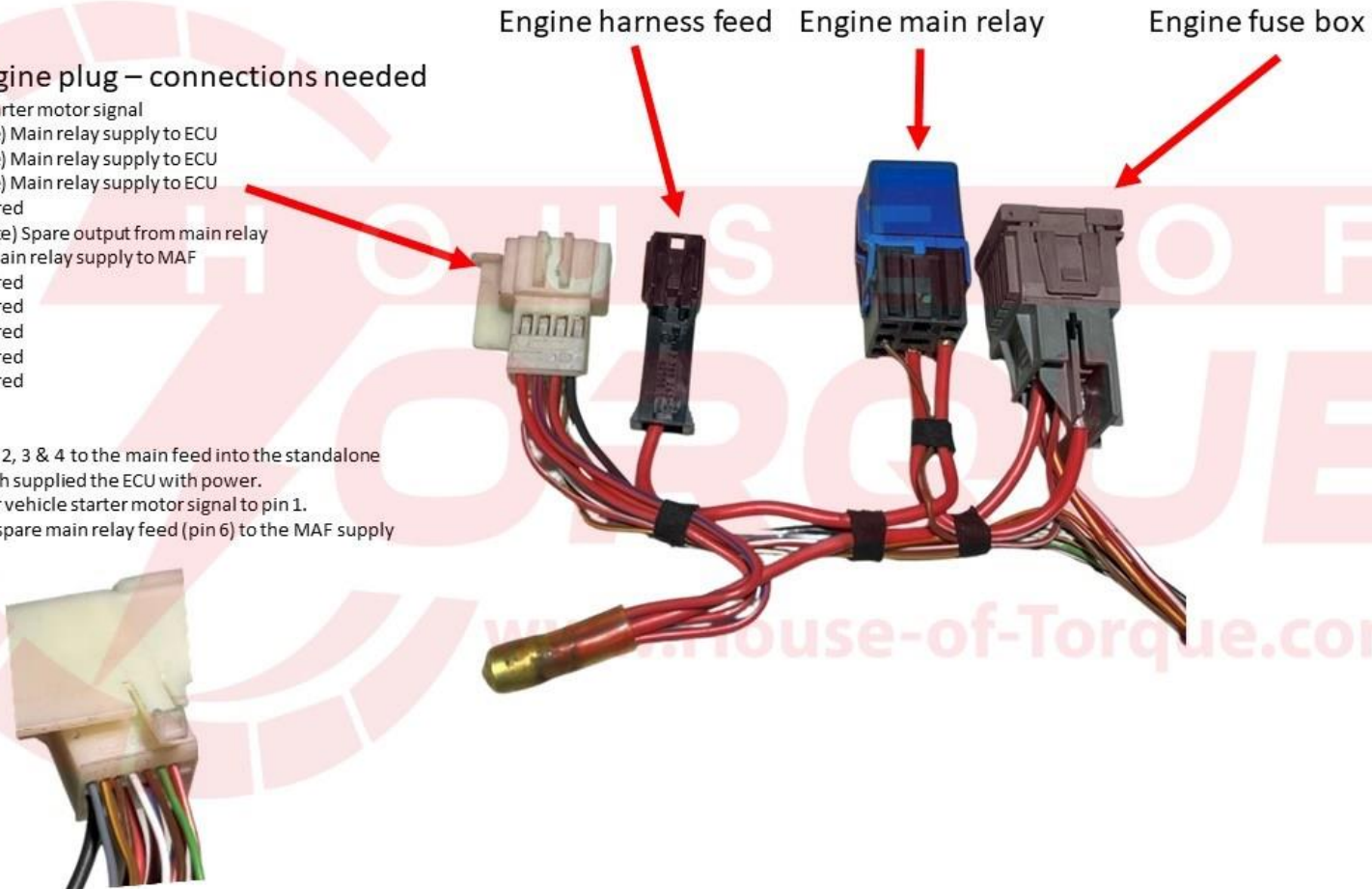

E70 TU2 Engine

A6011 Engine plug – connections needed

1. (Red/Blue) Main relay supply to ECU
2. (Black) Starter motor signal
3. (Red/Blue) Main relay supply to ECU
4. (Red/Blue) Main relay supply to ECU
5. (Green) Main relay supply to MAF
6. Not required
7. Not required
8. Not required
9. Not required
10. Not required
11. (Red/white) Spare output from main relay
12. Not required

Instructions:

- Connect pins 1, 3 & 4 to the main feed into the standalone harness which supplied the ECU with power
- Connect your vehicle starter motor signal to pin 2
- Connect the spare main relay feed (pin 11) to the MAF supply (pin 5)

